

# XPR-9

## Narrow or Wide Versions

### 2 POST LIFTS

**Compressor & Vehicle Lift  
Services Ltd**

Tel: 024 76491973

| [Email: info@garageequipmentdirect.co.uk](mailto:info@garageequipmentdirect.co.uk)

[www.garageequipmentdirect.co.uk](http://www.garageequipmentdirect.co.uk)

**2 year full warranty, Unique 5 year structural warranty**  
**New adjustable width design for**  
**narrow or wide configuration**



**New Features:**  
**Shorter columns**

**Twin locks on each column**

- 9,000lb lifting capacity
- Short column for low ceiling installations
- 4x4 and van adapters supplied F.O.C.
- Wide or narrow configuration
- Single piece columns
- Single point safety release
- Drop end arms provide a lower pad height
- Large, 20" x 19" steel base plates
- Automatic arm restraints
- ETL approved
- 5 year structure warranty
- Heavy duty dual 3/8" equalizer cables with oversize sheaves
- Triple telescoping arms provide increased range for lifting point access
- Electric/hydraulic power system
- Large, 20" x 19" steel base plates
- Chain lifting system combined with dual hydraulic cylinders
- Self lubricating dura glide polyethylene bearing system

**Single or 3 phase—same cost**  
**3 phase motor requires a 20amp supply**  
**Single phase motors require a 30amp supply**

TWO POST LIFTS

# TWO POST LIFTS

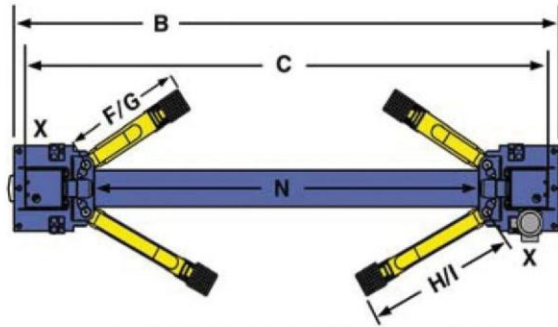

NOTE: Power unit can be located at either X location.

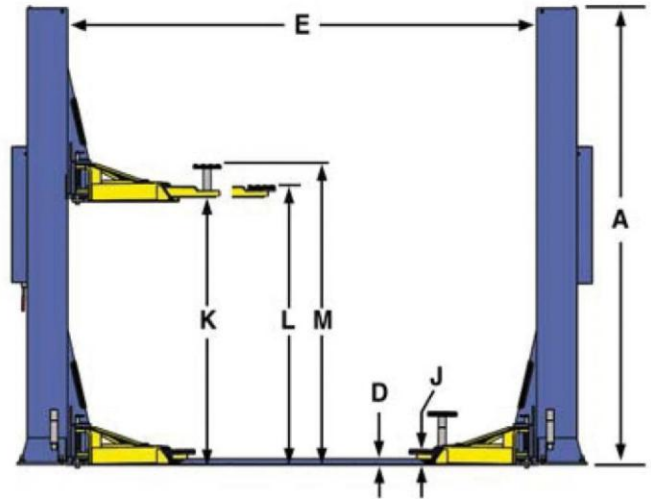

MODEL	XPR-9
Lifting Capacity*	9,000 lbs. / 4082 kg.
*Max Capacity / Front Axle	4,500 lbs. / 2041 kg.
*Max Capacity / Rear Axle	4,500 lbs. / 2041 kg.
<b>A</b> - Height Overall: (*)	113" / 2870 mm.
<b>B</b> - Width Overall: (NARROW CONFIGURATION)	132" / 3353 mm.
<b>B</b> - Width Overall: (WIDE CONFIGURATION)	145" / 3683 mm.
<b>C</b> - Width Outside of Columns: (NARROW CONFIGURATION)	126-3/4" / 3225 mm.
<b>C</b> - Width Outside of Columns: (WIDE CONFIGURATION)	139-3/4" / 3555 mm.
<b>D</b> - Floor Pan Height:	1-1/4" / 32 mm.
<b>E</b> - Inside Columns: (NARROW CONFIGURATION)	105" / 3208 mm.
<b>E</b> - Inside Columns: (WIDE CONFIGURATION)	118" / 3538 mm.
<b>F</b> - Reach (Front Arm Min.):	27-1/2" / 698 mm.
<b>G</b> - Reach (Front Arm Max.):	51-1/2" / 1308 mm.
<b>H</b> - Reach (Rear Arm Min.):	34" / 863 mm.
<b>I</b> - Reach (Rear Arm Max.):	54-1/2" / 1384 mm.
<b>J</b> - Min. Pad Height:	4" / 102 mm.
<b>K</b> - Rise:	72" / 1829 mm.
<b>L</b> - Max Lift Height (Pad Only):	76" / 1930 mm.
<b>M</b> - Max Lift Height (6" Adapter):	82" / 2083 mm.
<b>N</b> - Drive-Thru Clearance: (NARROW CONFIGURATION)	93" / 2362 mm.
<b>N</b> - Drive-Thru Clearance: (WIDE CONFIGURATION)	106" / 2692 mm.
Motor (**)	220 VAC / 60 Hz. 1Ph.
Time of full Rise:	45 Seconds
Max Load Per Arm:	2,250 Lbs. / 1021 Kg.

Our newest line of XPR-Series 2-Post Car Lifts is designed to provide pros and hobbyists alike with a wide selection of durable, safe and reliable systems for virtually every lifting application. Powerful and secure, BendPak's XPR-9 in particular has an incredibly rapid lifting speed and a robust menu of features to increase efficiency and productivity, but with fewer serviceable parts and reduced necessary maintenance. The results are lower operating expenses and higher productivity. If you're looking to do more in less time than ever before, you'll find that the short-style XPR-9 automobile lift is the perfect addition to your shop.

This two-post model has the capacity to effortlessly lift some of your largest full-sized pickups and commercial vehicles, yet it still provides specific capabilities for sport and compact cars, both foreign and domestic. The XPR-9 car lift is a rugged, open-top model lift with a 9,000-lb. maximum capacity. And when it comes to ease of use, our dual-synchro equalization system and user-friendly controls are the stuff of legends. Some other BendPak XPR-Series exclusives include: 16 individual maintenance-free UHMW load bearings, single-piece columns, extra-tall lifting carriages and oversized 5" cable sheaves. And, to better cater to your specific lifting needs, we offer optional specialty arm configurations.

The entire XPR-Series is a reflection of BendPak's continuing commitment to producing lifts of highest quality, safety and utmost reliability. Featuring the most advanced engineered technology available in the industry, these lifts are built to safety standards well above normal OSHA/ALI/ETL requirements. The XPR-Series car lifts include a wealth of standard and optional features to support the operator's need for performance and security. Combined with BendPak's tradition durable construction, the XPR-Series has become the new industry benchmark that others are judged by.

Whatever your specific automotive project requirements are, there's a BendPak XPR-Series 2-Post Car Lift designed to meet your needs. The XPR-Series is designed around an abundant roster of options and accessories that allow you to fully tailor your auto lift to your unique circumstance. But long before you start looking at options, you'll be impressed with the long list of standard features and capabilities packed into every BendPak XPR-Series Car Lift.

Bottom line—when you buy BendPak, you can expect a significant boost in performance and lift operation life expectancy because your BendPak XPR-9 is built to be the last lift you ever purchase. No one surpasses us in quality and safety—not now, not ever. That's why when you get a BendPak car lift; you get more than just a great lift. You get peace of mind. That's the benefit of owning a BendPak.

Getting the right lift for your application is easy with the help of your local BendPak dealer or by investigating the customer-focused product materials found on our website.

### **Every XPR-9 two-post car lift comes with:**

#### **Low-profile, dropped-end frame contact pads**

Squeeze under even the lowest compact and sport vehicles.

#### **Free truck and van adapters**

Other lift manufacturers might charge extra for these necessary adapters, but come standard with every XPR-Series Car Lift. Ideal for use with trucks and vans that employ running boards or auxiliary fuel tanks.

#### **Lowered arm tube supports**

To minimize the chance of damaging vehicles with low-hanging vehicle doors, we completely redesigned our two-post lift arm tube supports to allow for better clearance.

#### **Automatic arm restraints**

Each lifting arm is equipped with durable lift arm restraints that automatically engage each time the lift is raised. When the two-post auto lift is lowered, the gear arm restraints automatically disengage to provide easy positioning of the lift arms.

#### **Taller lift carriages**

Take a close look at our two-post car lift carriages (the lifting assembly that the arms are attached to). Now take a look at the competition. You'll notice our 53" tall carriages are considerably taller than most, which minimizes the stress placed on the load bearings and columns.

#### **Maintenance-free load bearings**

Rather than using roller bearings that need to be constantly lubricated, every XPR-Series Lift carriage uses high-tech UHMW (ultra-high molecular weight polyethylene) load bearings that never need lubrication and are designed to last the entire life of the lift.

#### **Single-piece columns**

We specifically manufacture the columns using single-piece construction for added strength and less fatigue under heavy load conditions.

### **Wide or narrow selection**

Wide or narrow car lift configurations are available, allowing you to maximize your floor space.

### **Single-point safety release**

The single point safety release and "dead man" style operation controls make every one of our XPR-Series Car & Truck Lifts easy to operate and safe to use.

### **On the level**

Our dual-synchro equalization system maintains equal lifting and provides operators with a stable, level vehicle working condition.

### **Industrial-grade hydraulic cylinders**

Integrated into every XPR-Series hydraulic cylinder is a one-piece, pilot fitted, machined steel piston that is wrapped with specially designed, pressure loaded U-cup piston seals, backups and wear bands that virtually eliminate any fluid bypass. The micro-smooth chrome rod is machined from high-yield, ground and polished C-1045/50 micro-alloy steel and plated to a minimum of .001" diametrically, ensuring superior cylinder operation and life. The superior high durometer, mechanically-loaded rod seals make rod leakage a thing of the past while a specially formulated abrasion-resistant urethane rod wiper provides exclusion protection. The welded cylinder body is made from robust steel tubing produced to exceed ASTM specifications. This combination of superb base material and superior processing ensures that the cylinders remain straight, smooth and last a very long time.

### **High-speed hydraulics**

Free-flow, high-pressure 3/8" hydraulic lines, a high-flow pump and integrated AC power-unit increase ascent and descent speed rates for enhanced productivity.

### **Durable powder-coat finish**

All XPR-Series Car Lifts feature a durable powder-coat finish that gives the metal a high-quality, extremely durable finish which can withstand even the harshest environmental or chemical conditions. Unlike other companies that claim to powder coat, we take pride in our meticulous 10-step process. First, all parts are visually inspected before being sandblasted. Afterwards, the parts are washed in our 5-stage phosphate tanks that can accommodate parts up to 25' long. Once cleaned, they're immediately dried to avoid rust production, and then outgassed. Outgassing pre-bakes the parts in a curing oven, reducing the possibility of blemishes that may be hiding in the pores of the metal. If not properly outgassed, imperfections in the metal may bubble during the curing process and most likely will cause chips in the powder. After the parts are washed and outgassed, any surfaces and / or threaded holes that need to be masked or plugged, are done so with high-temperature masking tape and silicone plugs. Next, the parts are given a quick thinner wipe to remove any light debris or fingerprints, before being hung on an electrostatically grounded conveyor line. The powder is finally applied using an electrostatic spray gun. The powder "sticks" to the surface in a fashion similar to how dust sticks to a television screen. Once the parts are powder coated, the carts are rolled into our curing oven and baked at 400° F for 45 minutes.



### **Compressor & Vehicle Lift Services Ltd**

Tel: 024 76491973

Fax 024 76749655

Email: [info@garageequipmentdirect.co.uk](mailto:info@garageequipmentdirect.co.uk)

[www.garageequipmentdirect.co.uk](http://www.garageequipmentdirect.co.uk)